

BS 6004:2012



BSI Standards Publication

# Electric cables – PVC insulated and PVC sheathed cables for voltages up to and including 300/500 V, for electric power and lighting

NO COPYING WITHOUT BSI PERMISSION EXCEPT AS PERMITTED BY COPYRIGHT LAW

*raising standards worldwide™*



**Publishing and copyright information**

The BSI copyright notice displayed in this document indicates when the document was last issued.

© The British Standards Institution 2012

Published by BSI Standards Limited 2012

ISBN 978 0 580 75844 7

ICS 29.060.20

The following BSI references relate to the work on this standard:

Committee reference GEL/20/17

Draft for comment 12/30248753 DC

**Publication history**

First published August 1969

Second edition, January 1976

Third edition, May 1984

Fourth edition, October 1990

Fifth edition, November 1991

Sixth edition, December 2000

Seventh (present) edition, September 2012

**Amendments issued since publication**

<b>Date</b>	<b>Text affected</b>
-------------	----------------------

---

## Contents

1	Scope	1
2	Normative references	1
3	Terms and definitions	2
4	Rated voltage	3
5	Construction	3
6	Conductors	3
7	Insulation	3
8	Identification of cores	4
9	Multi-core circular cables	5
10	Sheath	5
11	Cable marking and additional information	6
12	Schedule of tests	7
13	Test conditions	7
14	Routine tests	8
15	Sample tests	9
16	Type tests	10

### Annexes

Annex A (informative)	Coding cross references	17
Annex B (informative)	Traditional UK cables transferred to BS EN 50525	18
Annex C (informative)	Guide to use	20
Annex D (normative)	Compatibility test	23
Annex E (normative)	Method of test for voltage withstand	24
Annex F (informative)	Notes on type tests	24

### List of figures

Figure 1	An example of the marking as used on the outer sheath of the cable	7
----------	--	---

### List of tables

Table 1	Maximum permitted voltages against rated voltage of cable	3
Table 2	Schedule of tests	8
Table 3	PVC insulated, PVC sheathed cable, 300/500 V, single core 6181Y, flat twin 6192Y and flat 3-core 6193Y	12
Table 4	PVC insulated, PVC sheathed cable with circuit protective conductor (CPC), 300/500 V, single core 6241Y, flat twin 6242Y and flat 3-core 6243Y	13
Table 5	PVC insulated, PVC sheathed cable with or without circuit protective conductor (CPC), 300/500 V, single core 6241Y and flat twin (6192Y and 6242Y) (alternative conductor versions)	14
Table 6	Ordinary duty low temperature PVC insulated and PVC sheathed flexible cable, flat twin 3192A, circular 2-core 3182A, 3-core 3183A, 4-core 3184A and 5-core 3185A, 300/500 V	15
Table A.1	UK and harmonized CENELEC coding cross references: BS 6004	17
Table A.2	UK and harmonized CENELEC coding cross references: BS 7919	17
Table B.1	Standard PVC conduit cable: formerly in BS 6004	18
Table B.2	Standard PVC flexible cable: formerly in BS 6500	19
Table C.1	Construction details, method of installation and temperature for Table 3 to Table 5	21
Table C.2	Construction details, method of installation and temperature for Table 6	22
Table C.3	Guide to use	23
Table D.1	Compatibility requirements	23

### Summary of pages

This document comprises a front cover, an inside front cover, pages i to iv, pages 1 to 26, an inside back cover and a back cover.

## Foreword

### Publishing information

This British Standard is published by BSI Standards Limited, under licence from The British Standards Institution, and comes into effect on 1 January 2013. It was prepared by Subcommittee GEL/20/17, *Low voltage cables*, under the authority of Technical Committee GEL/20, *Electric cables*. A list of organizations represented on this committee can be obtained on request to its secretary.

### Supersession

This British Standard supersedes BS 6004:2000 (incorporating Amendments Nos. 1 and 2) and partially supersedes BS 7919:2001 (incorporating Amendments Nos. 1, 2 and 3), which are to be withdrawn on 31 December 2012.

### Relationship with other publications

The new edition takes account of:

- BS EN 60228 (replacing BS 6360) on conductors;
- BS EN 50363-3 (replacing BS 7655-3.1) on materials;
- BS EN 50395 (replacing Annex C of BS 6004:2000) on electrical tests;
- BS EN 50396 (replacing Annex D of BS 6004:2000) on thickness measurement;
- BS EN 60332-1-2 (replacing BS EN 50265-2-1);
- BS EN 62230 (replacing BS EN 50356) on spark testing.

### Information about this document

In the preparation of BS 6004, GEL/20/17 has requested that references to other standards for which the committee is responsible are undated, even if referring to a specific clause. It is the committee's intention not to amend the fundamentals (e.g. clause numbers, material type designation) in any of these standards and so the latest edition applies.

This is a full revision of the standard, which has been revised due to the conversion of CENELEC Harmonization Documents HD 21 and HD 22 to BS EN 50525 (all parts). The previous edition of BS 6004 included a number of cable types that were harmonized and marked with CENELEC harmonized code designations. The following cables are now included in BS EN 50525 (all parts) and withdrawn from BS 6004, which now only contains national types:

- PVC insulated, non-sheathed general purpose cable, single core (H07V-U, H07V-R and H07V-K) 450/750 V;
- PVC insulated, non-sheathed cable for internal wiring, single core (H05V-U, H05V-R and H05V-K) 300/500 V;
- PVC insulated, non-sheathed, heat-resisting cable, for internal wiring, single core (H05V2-U, H05V2-R and H05V2-K) 300/500 V;
- PVC insulated, non-sheathed, heat-resisting cable, for internal wiring, single core (H07V2-U, H07V2-R and H07V2-K) 450/750 V;
- oil resisting PVC sheathed, screened cables, having between 2 and 60 cores (H05VVC4V5-K) 300/500 V.

The following cables have also been withdrawn from BS 6004 following withdrawal by CENELEC:

- PVC insulated, non-sheathed cable, single core for installation at low temperatures (H07V3-U, H07V3-R and H07V3-K) 450/750 V.

The content of BS 6004 has been aligned with that found in BS EN 50525, where appropriate.

This edition of BS 6004 includes ordinary duty low temperature PVC insulated and sheathed flexible cable, parallel twin, circular twin, 3-core, 4-core and 5-core, 300/500 V from BS 7919:2001, Table 44 <sup>1)</sup>, which have the traditional United Kingdom Cable Codes of 3192A, 3182A, 3183A, 3184A and 3185A and are normally used for reduced voltage applications on building sites.

Annex A has been included to provide further clarification on where information from BS 6004:2000 and BS 7919:2001 has been moved to in this edition of BS 6004 and BS EN 50525-2-31. Annex B has been included to provide clarification on which cables have been transferred to BS EN 50525 (all parts).

The importance of the relationship between the traditional United Kingdom Cable Code (formerly known as the CMA coding) and its equivalent harmonized CENELEC code designations is emphasized. This additional information helps the user to choose the appropriate cable.

**Product certification/inspection/testing.** Users of this British Standard are advised to consider the desirability of third-party certification/inspection/testing of product conformity with this British Standard. Users seeking assistance in identifying appropriate conformity assessment bodies or schemes may ask BSI to forward their enquiries to the relevant association.

### Hazard warnings

**WARNING.** This British Standard calls for the use of substances and/or procedures that can be injurious to health if adequate precautions are not taken. It refers only to technical suitability and does not absolve the user from legal obligations relating to health and safety at any stage.

### Use of this document

It has been assumed in the preparation of this British Standard that the execution of its provisions will be entrusted to appropriately qualified and experienced people, for whose use it has been produced.

### Presentational conventions

The provisions in this British Standard are presented in roman (i.e. upright) type. Its requirements are expressed in sentences in which the principal auxiliary verb is "shall".

*Commentary, explanation and general informative material is presented in smaller italic type, and does not constitute a normative element.*

### Contractual and legal considerations

This publication does not purport to include all the necessary provisions of a contract. Users are responsible for its correct application.

**Compliance with a British Standard cannot confer immunity from legal obligations.**

<sup>1)</sup> BS 7919:2001 has been withdrawn and replaced by BS EN 50525-1, BS EN 50525-2-11, BS EN 50525-2-21, BS EN 50525-2-51, BS EN 50525-2-83 and BS EN 50525-3-21.



## 1 Scope

This British Standard specifies requirements and test methods for the construction and performance of cables that:

- a) have a polyvinyl chloride (PVC) insulation of rated voltage 300/500 V;
- b) are intended for electric power and lighting.

The types of cable included in this British Standard are:

- PVC insulated, PVC sheathed cable 300/500 V, single-core 6181Y, flat-twin 6192Y and 3-core 6193Y (see Table 3);
- PVC insulated, PVC sheathed cable with circuit protective conductor, 300/500 V, single-core 6241Y, flat-twin 6242Y and 3-core 6243Y (see Table 4);
- PVC insulated, PVC sheathed cable with or without circuit protective conductor, 300/500 V, single-core 6192Y, 6241Y and flat-twin 6242Y (alternative conductor versions) (see Table 5);
- ordinary duty low temperature PVC insulated, PVC sheathed flexible cable, 300/500 V, flat-twin 3192A, circular-twin 3182A, 3-core 3183A, 4-core 3184A and 5-core 3185A (see Table 6).

The insulation and other components are suitable to permit operation of the cables at a maximum sustained conductor temperature of 70 °C and for a maximum short-circuit conductor temperature of 160 °C (for a maximum period of 5 s).

*NOTE 1 Limitation on the temperature of the cables may be imposed in situations where they could be touched or where they could touch other materials.*

*NOTE 2 In installations that include wiring accessories, junction boxes and consumer units etc., the performance of these accessories should be taken into account in deciding the maximum operating temperature of the cable.*

*NOTE 3 Annex A provides a guide to the cross-referencing of the traditional United Kingdom Cable Codes (formerly known as the CMA codes) and harmonized CENELEC codes. Furthermore, Annex B gives information on the traditional UK cables transferred to BS EN 50525.*

*NOTE 4 Annex C gives guidance on the use of the cables specified in this British Standard.*

*NOTE 5 Annex D gives the compatibility test method.*

*NOTE 6 Annex E gives the voltage withstand test.*

*NOTE 7 Annex F gives notes on type tests.*

## 2 Normative references

The following documents, in whole or in part, are normatively referenced in this document and are indispensable for its application. For dated references, only the edition cited applies. For undated references, the latest edition of the referenced document (including any amendments) applies.

BS 5099, *Electric cables – Voltage levels for spark testing*

BS 7655-4.2, *Specification for insulating and sheathing materials for cables – Part 4: PVC sheathing compounds – Section 4.2: General application*

BS EN 50363-3, *Insulating, sheathing and covering materials for low voltage energy cables – Part 3: PVC insulating compounds*

BS EN 50395, *Electrical test methods for low voltage energy cables*

BS EN 50396, *Non electrical test methods for low voltage energy cables*

BS EN 60228, *Conductors of insulated cables*

BS EN 60332-1-2:2004, *Tests on electric and optical fibre cables under fire conditions – Part 1-2: Test for vertical flame propagation for a single insulated wire or cable – Procedure for 1 kW pre-mixed flame*

BS EN 60811-401, *Electric and optical fibre cables – Test methods for non-metallic materials – Part 401: Environmental tests – Thermal ageing methods – Ageing in an air oven*

BS EN 60811-501, *Electric and optical fibre cables – Test methods for non-metallic materials – Part 501: Mechanical tests – Tests for determining the mechanical properties of insulating and sheathing compounds*

BS EN 62230, *Electric cables – Spark-test method*

IEC 60050-461, *International Electrotechnical Vocabulary – Part 461: Electric cables*

### 3 Terms and definitions

For the purposes of this British Standard, the terms and definitions given in IEC 60050-461 and the following apply.

#### 3.1 cable manufacturer

organization that has the capability to both produce and control the conformity of cable made to this British Standard

*NOTE* See 11.1a) for information on marking the cable with the cable manufacturer's name and identifier.

#### 3.2 length of lay

axial length of one complete turn of the helix formed by one cable component

#### 3.3 nominal value

value by which a quantity is designated

*NOTE* Nominal values usually give rise to values to be checked by measurement taking into account specified tolerances.

#### 3.4 routine tests, R

tests made on all production lengths of cable to demonstrate their integrity

#### 3.5 sample tests, S

tests made on samples of completed cable, or components taken from a completed cable, adequate to verify that the finished product meets the design specifications

#### 3.6 type tests, T

tests made before supplying, on a general commercial basis, a type of cable covered by this British Standard, in order to demonstrate satisfactory performance characteristics to meet the intended application

*NOTE* These tests are of such a nature that, after they have been made, they need not be repeated unless changes are made in the cable materials, design or type of manufacturing process, which might change the performance characteristics.

#### 3.7 voltages

##### 3.7.1 maximum voltage, $U_m$

maximum sustained power-frequency voltage between phase conductors for which the cable is suitable



- 3.7.2 rated voltage,  $U_0$**   
nominal power-frequency voltage between conductor(s) and earth, for which the cable is suitable
- 3.7.3 rated voltage,  $U$**   
nominal power-frequency voltage between phase conductors for which the cable is suitable

## 4 Rated voltage

The cables shall be designated by the rated voltages  $U_0$  and  $U$ , expressed in the form  $U_0/U$ . The rated voltage recognized for the purpose of this British Standard shall be 300/500 V.

The maximum permanent permitted operating voltages of the system shall be in accordance with Table 1.

Table 1 Maximum permitted voltages against rated voltage of cable

Rated voltage of cable	Maximum permanent permitted operating voltage of the system			
	a.c.		d.c.	
	Conductor-earth $U_{0\max}$ (V)	Conductor-conductor $U_m$ (V)	Conductor-earth V	Conductor-conductor V
$U_0/U$ (V) 300/500	320	550	410	820

## 5 Construction

The construction of the cables shall be as specified in Table 3 to Table 6.

## 6 Conductors

The conductors shall be annealed copper conforming to BS EN 60228. The class of conductor shall be as given in Table 3 to Table 6.

## 7 Insulation

### 7.1 Type of insulation

The insulation shall be one of the following types, in accordance with Table 3 to Table 6:

- TI 1 as specified in BS EN 50363-3;
- TI 4 as specified in BS EN 50363-3.

### 7.2 Application

The insulation shall be applied by an extrusion process to form a compact and homogeneous layer.

*NOTE 1 The insulation can be applied in a single layer, or in a number of cohesive layers.*

Where more than one layer is used, all testing specified in this British Standard shall be carried out on the complete insulation as though it were a single layer of the declared insulation type (see 7.1).

*NOTE 2* Insulation applied in more than one layer does not conform to the definition of "double insulation" given, for instance, in BS 7671.

When the application is tested by removing the insulation from the conductor, there shall be no damage to the insulation itself or the conductor.

### 7.3 Thickness

The mean value of the radial thickness of the insulation, when measured in accordance with BS EN 50396, 4.1, shall be not less than the value given in Table 3 to Table 6. The smallest value measured,  $t_m$ , shall not fall below 90% of the value given in Table 3 to Table 6 by more than 0.1 mm, i.e.:

$$t_m \geq 0.9t_n - 0.1$$

where:

$t_m$  is the smallest value measured, in millimetres (mm);

$t_n$  is the tabulated radial thickness, in millimetres (mm).

## 8 Identification of cores

### 8.1 General

The cores of all cables shall be identified by colour. Each core shall be identified by its colour as indicated in Table 3 to Table 6.

*NOTE* Other colours may be used by agreement with the manufacturer; in this case the requirements in 11.2 do not apply.

### 8.2 Core colours

The colour shall be applied throughout either the whole insulation or the outer cohesive layer and shall be applied as part of the extrusion process.

The insulation of the coloured cores, irrespective of the method of colouring, shall be tested as a complete single layer (see 7.2).

The colours of the cores, determined by the number of cores in the cable, and also the sequence of the colours shall be as given in Table 3 to Table 6. Where alternative colours are used (see 8.1, Note), the sequence shall be agreed with the manufacturer.

On a core with the bi-colour combination of green-and-yellow, the distribution of these colours shall be such that for every 15 mm length of core one of these colours shall cover not less than 30% and not more than 70% of the surface of the core, while the other colour shall cover the remainder of the surface. Conformity shall be checked by measurement.

*NOTE 1* In cases of dispute regarding the green-and-yellow combination, and where appropriate to the method of colour marking of the insulation, a suitable test method for checking conformity is given in BS EN 50396, 5.2.

*NOTE 2* It is understood that the colours green and yellow, when they are combined as specified, are recognized as identifying exclusively the core intended for use as an earth connection or similar protection. The colour blue is for the identification of the core intended to be connected to neutral but, if there is no neutral, blue may be used to identify any core except for the earth or protective conductor.

*NOTE 3* Depending on where the cables are used, restrictions may apply to the use of certain colours for some applications.

### 8.3 Clarity and durability

The colour used for core identification shall be clearly identifiable and durable such that it cannot be removed when tested in accordance with BS EN 50396, 5.1.

## 9 Multi-core circular cables

The cores of the 2-core, 3-core, 4-core and 5-core circular cables shall be laid up together. Cores shall be laid up in the sequence of colours as given in Table 6. If alternative core colours to those specified in Table 6 are used, then an alternative sequence shall be agreed with the manufacturer.

Conformity shall be checked by visual examination.

The maximum length of lay for circular cables shall be not more than 25 times the diameter of the assembly of laid up cores.

Conformity shall be checked in accordance with 15.5.

## 10 Sheath

### 10.1 Type of sheath

The sheath shall be an extruded layer of PVC of one of the following types, in accordance with Table 3 to Table 6:

- Type 6 as specified in BS 7655-4.2.
- Type 10 as specified in BS 7655-4.2.

### 10.2 Application

The sheath shall be applied by an extrusion process.

*NOTE The sheath can be applied in a single layer or in a number of cohesive layers.*

Where more than one layer is used, all testing specified in this British Standard shall be carried out on the complete sheath as though it were a single layer of the declared sheath type (see 10.1).

When the sheath is removed, there shall be no damage to the core insulation when visually checked.

### 10.3 Thickness

When measured in accordance with BS EN 50396, 4.2 or 4.3, as applicable, the smallest value,  $t_m$ , of the radial thickness of the sheath shall not fall below 85% of the value given in Table 3 to Table 6 by more than 0.1 mm, i.e.:

$$t_m \geq 0.85t_n - 0.1$$

where:

$t_m$  is the smallest value measured, in millimetres (mm);

$t_n$  is the tabulated radial thickness, in millimetres (mm).

### 10.4 Colour

The colour shall be applied throughout either the whole sheath or the outer cohesive layer and shall be applied as part of the extrusion process.

The sheath, irrespective of the method of colouring, shall be tested as a complete single layer (see 10.2).

The colour of the sheath shall be as specified in Table 3 to Table 6.

# 11 Cable marking and additional information

## 11.1 External marking

The external surface of all cables conforming to this British Standard shall be legibly marked with the following elements:

Element	Example of marking
a) Cable manufacturer	Manufacturer's name and their unique factory identifier
<i>NOTE 1 A simplified version of the manufacturer's name, or a trading name of the manufacturer, may be used in place of the full name.</i>	
<i>NOTE 2 Any suitable method may be used to unambiguously identify the manufacturer's factory.</i>	
<i>NOTE 3 The manufacturer's own trademark or equivalent may be added but this cannot be used instead of the manufacturer's name or identifier.</i>	
b) Electric cable	ELECTRIC CABLE
c) Voltage designation	300/500 V
d) British Standard number	BS 6004 <sup>2)</sup>
e) UK cable code	6242Y
<i>NOTE 4 The relevant UK cable code is given in Table 3 to Table 6.</i>	
f) Number of cores, nominal area of conductor and circuit protective conductor as appropriate	i) 3 × 1.5 <sup>3)</sup> ii) 2 × 1.5 + 1.0 <sup>4)</sup>
g) Year of manufacture	ZZZZ
<i>NOTE 5 The year of manufacture may take the form of the actual year (e.g. 2013) or a coded year identifier assigned by the manufacturer.</i>	
h) Standard core colour identifier	H
<i>NOTE 6 See 11.2.</i>	

The marking of items a) to h) shall be by embossing or indenting on the sheath. The markings shall appear along the axis of the cable in any sequence that is deemed to neither confuse nor conflict.

*NOTE 7 The order in which the elements of marking appear along the length of the external sheath is not prescribed, but it is preferred that they be in the order a) to h) as shown in this subclause.*

The letters and figures shall consist of upright, block characters.

The distance between the end of one element of the marking and the beginning of the next identical element of the marking shall be not more than 550 mm in accordance with Figure 1.

Conformity of the marking shall be checked by visual examination and measurement of at least two sets of elements.

<sup>2)</sup> Marking BS 6004 or BS 6004:2012 on or in relation to a product represents a manufacturer's declaration of conformity, i.e. a claim by or on behalf of the manufacturer that the product meets the requirements of the standard. The accuracy of the claim is solely the claimant's responsibility. Such a declaration is not to be confused with third-party certification of conformity.

<sup>3)</sup> 3 × 1.5 indicates a 3-core cable with 1.5 mm<sup>2</sup> conductors.

<sup>4)</sup> 2 × 1.5 + 1.0 indicates a 2-core cable with 1.5 mm<sup>2</sup> conductors and a 1.0 mm<sup>2</sup> CPC.

Figure 1 An example of the marking as used on the outer sheath of the cable

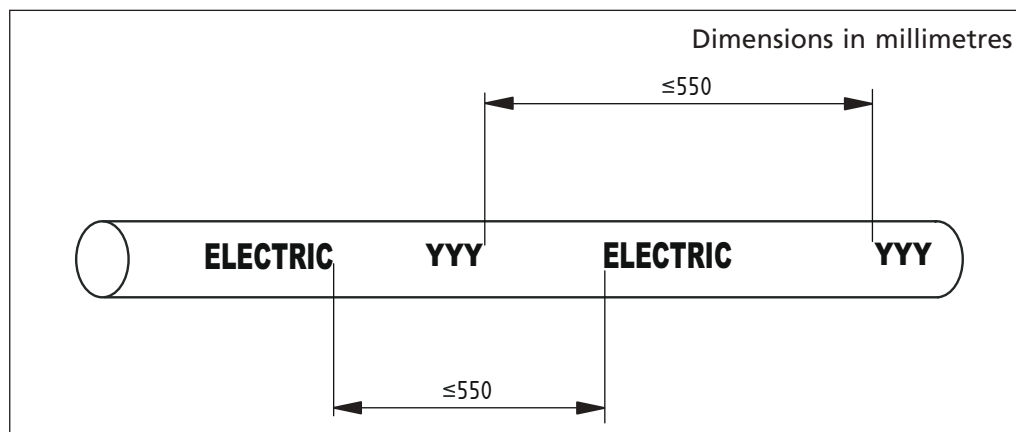

### 11.2 Standard core colour identifier

When the core colour combinations are used in accordance with Table 3 to Table 6, the letter "H" shall be included in the marking on the external sheath of the cable in accordance with 11.1.

### 11.3 The mark of an approval organization

If the mark of an approval organization is used, it shall be embossed or indented throughout the length of the external sheath of the cable.

The mark shall be in the form of symbol(s) specified by the approval organization, and the maximum distance between marks shall be not greater than 1 100 mm.

### 11.4 Additional information

Any additional information shall be embossed, indented or printed throughout the length of the external sheath of the cable.

The additional information shall be in one continuous string so that it does not conflict with, confuse nor render illegible the marking in 11.1, 11.2 and 11.3. The repeat interval shall not exceed 1 100 mm.

Where the information is applied by printing, it shall be durable so that it cannot be removed when tested in accordance with BS EN 50396, 5.1.

## 12 Schedule of tests

The tests to be performed on cables specified in this British Standard shall be as specified in Table 2, which refers to the relevant clauses of the standard specifying the requirements and test methods as well as the category of each test which applies, i.e. T, S or R (as defined in Clause 3).

## 13 Test conditions

### 13.1 Temperature

Tests shall be performed at a temperature of  $(20 \pm 15) ^\circ\text{C}$  unless otherwise specified in the details for a particular test.

### 13.2 Frequency and waveform of power frequency test voltages

The frequency of the alternating test voltages shall be in the range of 49 Hz to 61 Hz unless otherwise specified in the details for a particular test. The waveform shall be substantially sinusoidal.

Table 2 Schedule of tests

Test	Requirements given in clause	Test method	Test category
Conductor construction	Clause 6	BS EN 60228	S
Insulation:			
• material	7.1	BS EN 50363-3	T
• application	7.2	Visual examination and manual test	S
• thickness	7.3	BS EN 50396, 4.1	S
Core identification:			
• colour	8.2	Visual examination	S
• clarity and durability	8.3	BS EN 50396, 5.1	S
• assembly and core colour sequence	Clause 9	Visual examination	S
Length of lay of assembled cores	Clause 9	15.5	S
Sheath:			
• material	10.1	BS 7655-4.2	T
• application	10.2	Visual examination	S
• thickness	10.3	BS EN 50396, 4.2 or 4.3	S
• colour	10.4	Visual examination	S
Cable marking	Clause 11	Visual examination and measurement	S
Durability of printed information	11.4	BS EN 50396, 5.1	T
Conductor resistance	14.2	BS EN 60228	R
Absence of faults on the insulation	14.3	BS EN 62230, BS EN 50395, 10.3	R
Mean overall dimensions	15.2	BS EN 50396, 4.4	S
Ovality	15.3	BS EN 50396, 4.4	S
Voltage withstand	15.4	Annex E	S
Insulation resistance	16.2	BS EN 50395, 8.1	T
Voltage test on cores	16.3	BS EN 50395, Clause 7	T
Long term resistance to d.c.	16.4	BS EN 50395, Clause 9	T
Compatibility	16.5	Annex D	T
Flame propagation on single cable	16.6	BS EN 60332-1-2	T
Flexing test	16.7	BS EN 50396, 6.2, BS EN 50395, Clause 7	T

NOTE 1 Tests classified as sample (S) or routine (R) might be required as part of a type approval scheme.

NOTE 2 The order of the tests in this schedule does not imply a sequence of testing.

## 14 Routine tests

### COMMENTARY ON Clause 14

*In some tests, the preparation and presentation of the test sample can have a critical affect on the result of the tests so test samples should always be prepared carefully.*

### 14.1 General

Routine tests shall be performed in accordance with Table 2 as indicated by the symbol "R" in column 4.

*NOTE* The requirements for routine testing that are not fully covered by earlier clauses are detailed in 14.2 and 14.3.

## 14.2 Conductor resistance

The d.c. resistance of each conductor shall conform to BS EN 60228 when measured in accordance with BS EN 60228, Annex A, and corrected to 20 °C. The measurement shall be made on a complete drum length or on a 1 m sample taken from the drum.

## 14.3 Test to check the absence of faults on the insulation

### 14.3.1 Test for single-core circular cable

The completed single-core circular cable shall be tested in accordance with the a.c. or d.c. test method in BS EN 62230 at the test voltage stated in BS 5099, 5.3, (insulation and sheath combined) and there shall be no breakdown of the insulation or sheath.

### 14.3.2 Test for flat cable and multi-core circular cable

The completed flat cable or multi-core circular cable shall be tested in accordance with BS EN 50395, 10.3, having either a test voltage of 2 000 V a.c. r.m.s. or 5 000 V d.c., for 5 minutes and there shall be no breakdown of the insulation.

Single-core flat cable, with an uninsulated circuit protective conductor (6241Y) shall have the test voltage applied to the core, and the uninsulated circuit protective conductor shall be earthed.

## 15 Sample tests

### COMMENTARY ON Clause 15

*In some tests, the preparation and presentation of the test sample can have a critical affect on the result of the tests so test samples should always be prepared carefully.*

### 15.1 General

Sample tests shall be performed in accordance with Table 2 as indicated by the symbol "S" in column 4.

*NOTE* The requirements for sample testing that are not fully covered by earlier clauses are detailed in 15.2, 15.3, 15.4 and 15.5.

### 15.2 Mean overall dimensions

When tested in accordance with BS EN 50396, 4.4, the mean overall diameter of circular cables and the mean overall dimensions of flat cables shall be within the limits specified in Table 3 to Table 6.

A test sample shall be taken from a cable from three places, separated by not less than 1 m. For circular cables, the mean of the six values obtained shall be taken as the mean overall diameter. For flat cables, the mean of each set of three values, for the major and minor axis, respectively, shall be taken as the relevant overall dimension.

### 15.3 Ovality of circular cables

The difference between any two values of the overall diameter of circular sheathed cables at the same cross-section shall not exceed 15% of the upper limit for the mean overall diameter given in Table 3 and Table 6 when tested in accordance with BS EN 50396, 4.4.

A test sample shall be taken from a cable from three places, separated by not less than 1 m.

Two measurements shall be taken at the same cross-section of the cable, covering the maximum and minimum values.

#### 15.4 Voltage withstand

When tested in accordance with Annex E, no breakdown of the insulation shall occur.

#### 15.5 Length of lay

The length of lay shall be determined by measuring the length of two pitches of a laid up assembly taken from a sample of cable and calculating the average of these two lengths. The result shall be taken as the length of lay of the laid-up cores.

### 16 Type tests

*COMMENTARY ON Clause 16*

*In some tests, the preparation and presentation of the test sample can have a critical affect on the result of the tests so test samples should always be prepared carefully.*

#### 16.1 General

Type tests shall be performed in accordance with Table 2 as indicated by the symbol "T" in column 4.

*NOTE 1 The requirements for type testing that are not fully covered by earlier clauses are detailed in 16.2, 16.3, 16.4, 16.5, 16.6, and 16.7.*

*NOTE 2 Informative notes on type tests can be found in Annex F.*

#### 16.2 Insulation resistance

When the cores are tested in accordance with BS EN 50395, 8.1, under the following conditions:

- a) period of immersion in water: minimum 2 h;
- b) temperature of water for cables in Tables 3, 4 and 5:  $(70 \pm 2)$  °C;
- c) temperature of water for cables in Table 6:  $(60 \pm 2)$  °C;

none of the resulting values shall be below the minimum insulation resistance value specified in Table 3 to Table 6.

#### 16.3 Voltage test on cores

When the cores are tested in accordance with BS EN 50395, Clause 7, under the following conditions:

- a) period of immersion in water: minimum 1 h;
- b) temperature of the water:  $(20 \pm 5)$  °C;
- c) applied voltage (a.c.) according to the tabulated thickness of insulation:
  - up to and including 0.6 mm: 1 500 V;
  - exceeding 0.6 mm: 2 000 V;
- d) duration of each application of voltage: minimum 5 min;

there shall be no breakdown of the insulation.



#### 16.4 Long term resistance to d.c.

When the cable is tested in accordance with BS EN 50395, Clause 9, under the following test conditions:

- a) temperature of the aqueous solution:  $(60 \pm 5)$  °C;
- b) applied voltage (d.c.): 220 V;
- c) period of immersion in the aqueous solution, and duration of application of voltage: minimum 240 h;

the insulation shall not break down nor shall the exterior of the insulation show damage. Discoloration of the insulation shall be ignored.

#### 16.5 Compatibility

When a sample of complete cable is aged in accordance with D.2, the insulation and the outer sheath shall conform to the requirements given in Table D.1. In addition, at the end of the test period in the oven, the blotting paper shall be free of stains.

#### 16.6 Flame propagation of a single cable

When tested in accordance with BS EN 60332-1-2, the completed cable shall conform to BS EN 60332-1-2:2004, Annex A.

#### 16.7 Two pulley flexing test

The cables in Table 6 shall be tested in accordance with BS EN 50396, 6.2, and BS EN 50395, Clause 7, and shall conform to the following requirements.

- a) During the test of 30 000 cycles, i.e. 60 000 single movements, there shall be:
  - no interruption of the current;
  - no short circuit between the conductors;
  - no short circuit between the cable and the pulley wheels (the flexing apparatus).
- b) After the required number of cycles the sheath shall be examined under normal or corrected vision.

There shall be no point at which any underlying component of the cable (for instance tapes, insulated cores, etc.) shall be visible through a break in the sheath. The sheath of the cable shall then be removed.

The cores from the cable, without its sheath, shall be tested in accordance with 16.3 and there shall be no breakdown of the insulation.

Table 3 PVC insulated, PVC sheathed cable, 300/500 V, single core 6181Y, flat twin 6192Y and flat 3-core 6193Y

## Construction:

- conductor: annealed copper conductor, class 1 and class 2 as shown in column 2;
- insulation: PVC type TI 1;
- sheath: PVC type 6.

## Colours for core identification:

- single core: brown or blue;
- twin: brown and blue, alternatively, for 2 × 1.0 and 2 × 1.5 cables, brown and brown;
- 3-core: brown, black (centre core) and grey.

## Position of CPC:

- twin: centrally placed between cores in same plane;
- 3-core: centrally placed between black and grey cores in same plane.

## Colour of sheath:

- grey (other colours may be used by agreement between manufacturer and customer).

Number and nominal cross-sectional area of conductors mm <sup>2</sup>	Class of conductor	Radial thickness of insulation mm	Radial thickness of sheath mm	Mean overall dimensions		Minimum insulation resistance at 70 °C mΩ·km
				Lower limits mm	Upper limits mm	
<b>6181Y</b>						
1 × 1.0	1	0.6	0.8	3.7	4.5	0.011
1 × 1.5	1	0.7	0.8	4.2	5.0	0.011
1 × 2.5	1	0.8	0.8	4.8	5.7	0.010
1 × 4	2	0.8	0.9	5.5	6.7	0.0077
1 × 6	2	0.8	0.9	6.0	7.3	0.0065
1 × 10	2	1.0	0.9	7.3	8.8	0.0065
1 × 16	2	1.0	1.0	8.4	10.1	0.0052
1 × 25	2	1.2	1.1	10.0	12.1	0.0050
1 × 35	2	1.2	1.1	11.1	13.5	0.0044
<b>6192Y</b>						
2 × 1.0	1	0.6	0.9	3.9 × 6.1	4.8 × 7.4	0.011
2 × 1.5	1	0.7	0.9	4.4 × 7.0	5.3 × 8.5	0.011
2 × 2.5	1	0.8	1.0	5.1 × 8.4	6.2 × 10.1	0.010
2 × 4	2	0.8	1.0	5.7 × 9.5	6.9 × 11.5	0.0077
2 × 6	2	0.8	1.1	6.4 × 10.8	7.8 × 13.0	0.0065
2 × 10	2	1.0	1.2	7.9 × 13.4	9.5 × 16.2	0.0065
2 × 16	2	1.0	1.3	8.9 × 15.4	10.8 × 18.6	0.0052
<b>6193Y</b>						
3 × 1.0	1	0.6	0.9	3.9 × 8.4	4.8 × 10.1	0.011
3 × 1.5	1	0.7	0.9	4.4 × 9.6	5.3 × 11.7	0.011
3 × 2.5	1	0.8	1.0	5.1 × 11.6	6.2 × 14.0	0.010
3 × 4	2	0.8	1.1	5.9 × 13.5	7.1 × 16.3	0.0077
3 × 6	2	0.8	1.1	6.4 × 15.1	7.8 × 18.2	0.0065
3 × 10	2	1.0	1.2	7.9 × 19.0	9.5 × 23.0	0.0065
3 × 16	2	1.0	1.3	8.9 × 21.8	10.8 × 26.3	0.0052

Table 4 PVC insulated, PVC sheathed cable with circuit protective conductor (CPC), 300/500 V, single core 6241Y, flat twin 6242Y and flat 3-core 6243Y

## Construction:

- conductor: annealed copper conductor, class 1 and class 2 as shown in column 2;
- insulation: PVC type TI 1;
- sheath: PVC type 6.

## Colours for core identification:

- single core: brown or blue;
- twin: brown and blue, alternatively, for 2 × 1.0 and 2 × 1.5 cables, brown and brown;
- 3-core: brown, black (centre core), and grey.

## Position of CPC:

- twin: centrally placed between cores in same plane;
- 3-core: centrally placed between black and grey cores in same plane.

## Colour of sheath:

- Grey (other colours may be used by agreement between manufacturer and customer).

Number and nominal cross-sectional area of conductors mm <sup>2</sup>	Class of conductor	Radial thickness of insulation mm	Radial thickness of sheath mm	Mean overall dimensions		CPC minimum nominal cross-sectional area mm <sup>2</sup>	Class of CPC	Minimum insulation resistance at 70 °C mΩ·km
				Lower limit mm	Upper limit mm			
<b>6241Y</b>								
1 × 1.0	1	0.6	0.9	3.9 × 5.0	4.8 × 6.0	1.0	1	0.011
1 × 1.5	1	0.7	0.9	4.4 × 5.4	5.3 × 6.6	1.0	1	0.011
<b>6242Y</b>								
2 × 1.0	1	0.6	0.9	3.9 × 7.2	4.8 × 8.7	1.0	1	0.011
2 × 1.5	1	0.7	0.9	4.4 × 8.1	5.3 × 9.7	1.0	1	0.011
2 × 2.5	1	0.8	1.0	5.1 × 9.6	6.2 × 11.7	1.5	1	0.010
2 × 4	2	0.8	1.0	5.7 × 10.8	6.9 × 13.1	1.5	1	0.0077
2 × 6	2	0.8	1.1	6.4 × 12.4	7.8 × 15.0	2.5	1	0.0065
2 × 10	2	1.0	1.2	7.9 × 15.6	9.5 × 18.9	4	2	0.0065
2 × 16	2	1.0	1.3	8.9 × 18.1	10.8 × 21.9	6	2	0.0052
<b>6243Y</b>								
3 × 1.0	1	0.6	0.9	3.9 × 9.4	4.8 × 11.4	1.0	1	0.011
3 × 1.5	1	0.7	0.9	4.4 × 10.7	5.3 × 12.9	1.0	1	0.011
3 × 2.5	1	0.8	1.0	5.1 × 12.6	6.2 × 15.3	1.5	1	0.010
3 × 4	2	0.8	1.1	5.9 × 14.8	7.1 × 17.9	1.5	1	0.0077
3 × 6	2	0.8	1.1	6.4 × 16.8	7.8 × 20.2	2.5	1	0.0065
3 × 10	2	1.0	1.2	7.9 × 21.3	9.5 × 25.7	4	2	0.0065
3 × 16	2	1.0	1.3	8.9 × 24.6	10.8 × 29.7	6	2	0.0052

*NOTE* When required by the purchaser, alternative conductor versions of certain sizes may be available in the form given in Table 5.

Table 5 PVC insulated, PVC sheathed cable with or without circuit protective conductor (CPC), 300/500 V, single core 6241Y and flat twin (6192Y and 6242Y) (alternative conductor versions)

Construction:

- conductor: annealed copper conductor, class 2 as shown in column 2;
- CPC: class 1;
- insulation: PVC type TI 1;
- sheath: PVC type 6.

Colours for core identification:

- single core: brown or blue;
- twin: brown and blue, alternatively, for 2 × 1.0 and 2 × 1.5 cables, brown and brown.

Position of CPC:

- twin: centrally placed between cores in same plane.

Colour of sheath:

- grey (other colours may be used by agreement between manufacturer and customer).

Number and nominal cross-sectional area of conductors mm <sup>2</sup>	Class of conductor	Radial thickness of insulation mm	Radial thickness of sheath mm	Mean overall dimensions		CPC minimum nominal cross-sectional area mm <sup>2</sup>	Class of CPC	Minimum insulation resistance at 70 °C mΩ·km
				Lower limit mm	Upper limit mm			
<b>6192Y</b>								
2 × 1.5	2	0.7	0.9	4.5 × 7.2	5.4 × 8.7	—	—	0.011
2 × 2.5	2	0.8	1.0	5.2 × 8.5	6.3 × 10.3	—	—	0.010
<b>6241Y</b>								
1 × 1.5	2	0.7	0.9	4.5 × 5.5	5.4 × 6.7	1.0	1	0.011
<b>6242Y</b>								
2 × 1.5	2	0.7	0.9	4.5 × 8.3	5.4 × 10.0	1.0	1	0.011
2 × 2.5	2	0.8	1.0	5.2 × 9.8	6.3 × 11.9	1.5	1	0.010

NOTE This table gives alternative conductor versions (class 2 conductors) of certain sizes of the cables given in Table 4.

Table 6 Ordinary duty low temperature PVC insulated and PVC sheathed flexible cable, flat twin 3192A, circular 2-core 3182A, 3-core 3183A, 4-core 3184A and 5-core 3185A, 300/500 V

Construction:

- conductors: annealed copper, class 5;
- insulation: compound type TI 4;
- sheath: compound type 10.

A centre filler of suitable material may be used except for twin cables. For circular cables, the cores and fillers, if any, shall be twisted together to give a practically circular cross-section. For flat cables, the cores shall be laid parallel. A separator may be used that shall not adhere to the cores.

The sheath may fill the outer interstices thus forming a filling but it shall not adhere to the cores.

Core identification and sequence:

- twin: blue and brown;
- 3-core: green-and-yellow, blue and brown;
- 4-core: green-and-yellow, brown, black, grey or green-and-yellow, blue, brown, black <sup>A)</sup>;
- 5-core: green-and-yellow, blue, brown, black, grey.

Colour of sheath:

- yellow or blue.

Number and nominal cross-sectional area of conductors mm <sup>2</sup>	Radial thickness of insulation mm	Radial thickness of sheath mm	Mean overall dimensions		Minimum insulation resistance at 60 °C mΩ·km
			Lower limit mm	Upper limit mm	
<b>3192A</b>					
2 × 0.75	0.6	0.8	3.4 × 5.7	4.5 × 7.2	0.011
2 × 1	0.6	0.8	3.6 × 5.9	4.7 × 7.5	0.010
<b>3182A</b>					
2 × 0.5	0.6	0.8	5.4	6.8	0.011
2 × 0.75	0.6	0.8	5.7	7.2	0.011
2 × 1	0.6	0.8	5.9	7.5	0.010
2 × 1.5	0.7	0.8	6.8	8.6	0.010
2 × 2.5	0.8	1.0	8.4	10.6	0.0095
2 × 4	0.8	1.1	9.7	12.1	0.0078
<b>3183A</b>					
3 × 0.75	0.6	0.8	6.0	7.6	0.011
3 × 1	0.6	0.8	6.3	8.0	0.010
3 × 1.5	0.7	0.9	7.4	9.4	0.010
3 × 2.5	0.8	1.1	9.2	11.4	0.0095
3 × 4	0.8	1.2	10.5	13.1	0.0078
<b>3184A</b>					
4 × 0.75	0.6	0.8	6.6	8.3	0.011
4 × 1	0.6	0.9	7.1	9.0	0.010
4 × 1.5	0.7	1.0	8.4	10.5	0.010
4 × 2.5	0.8	1.1	10.1	12.5	0.0095
4 × 4	0.8	1.2	11.5	14.3	0.0078

Table 6 Ordinary duty low temperature PVC insulated and PVC sheathed flexible cable, flat twin 3192A, circular 2-core 3182A, 3-core 3183A, 4-core 3184A and 5-core 3185A, 300/500 V

Construction:

- conductors: annealed copper, class 5;
- insulation: compound type TI 4;
- sheath: compound type 10.

A centre filler of suitable material may be used except for twin cables. For circular cables, the cores and fillers, if any, shall be twisted together to give a practically circular cross-section. For flat cables, the cores shall be laid parallel. A separator may be used that shall not adhere to the cores.

The sheath may fill the outer interstices thus forming a filling but it shall not adhere to the cores.

Core identification and sequence:

- twin: blue and brown;
- 3-core: green-and-yellow, blue and brown;
- 4-core: green-and-yellow, brown, black, grey or green-and-yellow, blue, brown, black <sup>A)</sup>;
- 5-core: green-and-yellow, blue, brown, black, grey.

Colour of sheath:

- yellow or blue.

Number and nominal cross-sectional area of conductors mm <sup>2</sup>	Radial thickness of insulation mm	Radial thickness of sheath mm	Mean overall dimensions		Minimum insulation resistance at 60 °C mΩ·km
			Lower limit mm	Upper limit mm	
<b>3185A</b>					
5 × 0.75	0.6	0.9	7.4	9.3	0.011
5 × 1	0.6	0.9	7.8	9.8	0.010
5 × 1.5	0.7	1.1	9.3	11.6	0.010
5 × 2.5	0.8	1.2	11.2	13.9	0.0095
5 × 4	0.8	1.4	13.0	16.1	0.0078

<sup>A)</sup> HD 308 allows for two alternative core identification methods for 4-core cables with a green-and-yellow core.

## Annex A (informative) Coding cross references

This annex has been included to assist users by linking the table references from BS 6004:2000 with the position of these cables either in BS 6004:2012 or in BS EN 50525-2-31; see Table A.1.

This annex also includes cross-references for the one national type given in BS 7919:2001 that has been transferred into BS 6004:2012; see Table A.2.

Table A.1 UK and harmonized CENELEC coding cross references: BS 6004

Location in BS 6004:2000	New location		UK code	CENELEC code
	Standard	Clause/Table		
Table 4a	BS EN 50525-2-31	4.1	6491X	H07V - U/R
Table 4b	BS EN 50525-2-31	4.2	6491X	H07V - K
Table 5	BS EN 50525-2-31	4.3	2491X	H05V - U/R
		4.4	2491X	H05V - K
Table 7	BS 6004:2012	Table 3	6181Y 6192Y 6193Y	—
Table 8	BS 6004:2012	Table 4	6241Y 6242Y 6243Y	—
Table 9	BS 6004:2012	Table 5	6192Y 6241Y 6242Y	—
Table 10a	Withdrawn	Withdrawn	—	H07V3 - U/R
Table 10b	Withdrawn	Withdrawn	—	H07V3 - K
Table 11a	BS EN 50525-2-31	5.1	6491XHR	H07V2 - U/R
Table 11b	BS EN 50525-2-31	5.2	6491XHR	H07V2 - K
Table 12	BS EN 50525-2-31	5.3, 5.4	2491XHR	H05V2 - U/R/K
Table 13	BS EN 50525-2-51	4.2	—	H05VVC4V5 - K

Table A.2 UK and harmonized CENELEC coding cross references: BS 7919

Location in BS 7919:2001	New location	UK code	CENELEC code
Table 44	BS 6004:2012, Table 6	3192A 3182A 3183A 3184A 3185A	—

Annex B  
(informative)**Traditional UK cables transferred to BS EN 50525**

Cables that have traditionally been included in British Standards, which were also harmonized, have been moved to BS EN 50525 (all parts).

For clarity and openness during this period of change, the cable types that have the most widespread applications in the United Kingdom have been included in this annex to aid understanding; see Tables B.1 and B.2.

Table B.1 Standard PVC conduit cable: formerly in BS 6004

Construction: plain copper conductor, PVC insulated only, 450/750 V

Traditional UK cable code: 6491X (solid)

Harmonized cable code: H07V - U

Traditional UK cable code: 6491X (rigid strand)

Harmonized cable code: H07V - R

Nominal cross-sectional area of conductors mm <sup>2</sup>	Class of conductor (BS EN 60228)	Thickness of insulation: specified value mm	Mean overall diameter		Minimum insulation resistance MΩ·km
			Lower limit mm	Upper limit mm	
1.5	1	0.7	2.6	3.2	0.011
1.5	2	0.7	2.7	3.3	0.010
2.5	1	0.8	3.2	3.9	0.010
2.5	2	0.8	3.3	4.0	0.0099
4	1	0.8	3.6	4.4	0.0087
4	2	0.8	3.8	4.6	0.0082
6	1	0.8	4.1	5.0	0.0074
6	2	0.8	4.3	5.2	0.0070
10	1	1.0	5.3	6.4	0.0072
10	2	1.0	5.6	6.7	0.0067
16	2	1.0	6.4	7.8	0.0056
25	2	1.2	8.1	9.7	0.0053
35	2	1.2	9.0	10.9	0.0046
50	2	1.4	10.6	12.8	0.0046
70	2	1.4	12.1	14.6	0.0040
95	2	1.6	14.1	17.1	0.0039
120	2	1.6	15.6	18.8	0.0035
150	2	1.8	17.3	20.9	0.0035
185	2	2.0	19.3	23.3	0.0035
240	2	2.2	22.0	26.6	0.0034
300	2	2.4	24.5	29.6	0.0033
400	2	2.6	27.5	33.2	0.0031
500	2	2.8	30.5	36.9	0.0030
630	2	2.8	34.0	41.1	0.0027
800	2	2.8	37.8	45.7	0.0024
1 000	2	3.0	42.1	51.0	0.0023

NOTE The information in this table has been extracted from BS EN 50525-2-31, Table B.1.



Table B.2 Standard PVC flexible cable: formerly in BS 6500

Construction: plain copper flexible conductor, PVC insulation, cores laid up, PVC sheath overall, 300/500 V

## Traditional UK cable code:

- 2 core cable 3182Y
- 3 core cable 3183Y
- 4 core cable 3184Y
- 5 core cable 3185Y

## Harmonized cable code:

- H05VV-F2
- H05VV-F3
- H05VV-F4
- H05VV-F5

Number and nominal cross-sectional area of conductors mm <sup>2</sup>	Thickness of insulation: specified value mm	Thickness of sheath: specified value mm	Mean overall dimensions		Minimum insulation resistance MΩ·km
			Lower limit mm	Upper limit mm	
2 × 0.75	0.6	0.8	5.7	7.2	0.011
2 × 1	0.6	0.8	5.9	7.5	0.010
2 × 1.5	0.7	0.8	6.8	8.6	0.010
2 × 2.5	0.8	1.0	8.4	10.6	0.0095
2 × 4	0.8	1.1	9.7	12.1	0.0078
3 × 0.75	0.6	0.8	6.0	7.6	0.011
3 × 1	0.6	0.8	6.3	8.0	0.010
3 × 1.5	0.7	0.9	7.4	9.4	0.010
3 × 2.5	0.8	1.1	9.2	11.4	0.0095
3 × 4	0.8	1.2	10.5	13.1	0.0078
4 × 0.75	0.6	0.8	6.6	8.3	0.011
4 × 1	0.6	0.9	7.1	9.0	0.010
4 × 1.5	0.7	1.0	8.4	10.5	0.010
4 × 2.5	0.8	1.1	10.1	12.5	0.0095
4 × 4	0.8	1.2	11.5	14.3	0.0078
5 × 0.75	0.6	0.9	7.4	9.3	0.011
5 × 1	0.6	0.9	7.8	9.8	0.010
5 × 1.5	0.7	1.1	9.3	11.6	0.010
5 × 2.5	0.8	1.2	11.2	13.9	0.0095
5 × 4	0.8	1.4	13.0	16.1	0.0078

NOTE The information in this table has been extracted from BS EN 50525-2-11, Table B.2.

**Annex C  
(informative)****Guide to use***COMMENTARY ON Annex C*

*This annex gives details on general technical guidance and is not intended as an interpretation of any UK statutory requirements, where these apply.*

None of the cable types specified in this British Standard are intended to be laid underground.

*NOTE 1 Installation requirements and current ratings are detailed in BS 7671.*

It is assumed that the design of installations and the specification, purchase and installation of cables specified in this British Standard is entrusted to suitably skilled and competent people.

Information on the specific cables in this British Standard is given in the form of limiting values (see Table C.1 and Table C.2) and is illustrated by examples (see Table C.3), which are not exhaustive but which indicate ways by which safety can be obtained.

*NOTE 2 BS 7540-1 gives general guidance for the use of cables.*

It is not practicable to include here all possible methods of installation that installers or users might adopt. If methods are adopted that are not recommended, then this could result in a reduction of safety and life expectancy of the cable. If a cable is intended to be used outside the recommended use, the cable manufacturer should be consulted for advice.

Table C.1 Construction details, method of installation and temperature for Table 3 to Table 5

Parameter	Unit	Table 3			Table 4			Table 5	
		6181Y <sup>A)</sup> 6192Y 6193Y	6181Y <sup>A)</sup> 2 1 4 to 35	6192Y <sup>A)</sup> 6193Y 2 2 to 3 4 to 16	6241Y <sup>A)</sup> 300/500 1 2 to 3 1 to 1.5	6242Y <sup>A)</sup> 6243Y 300/500 1 2 to 3 1 to 2.5	6242Y <sup>A)</sup> 6243Y 300/500 2 2 to 3 4 to 16	6241Y <sup>A)</sup> 300/500 2 1 1.5	6192Y <sup>A)</sup> 6242Y 300/500 2 2 1.5 to 2.5
<b>Constructional details:</b>									
Nominal voltage rating	V	300/500	300/500	300/500	300/500	300/500	300/500	300/500	300/500
Conductor class <sup>B)</sup>		1	2	2	1	2	1	2	2
Number of cores		1 to 3	1	2 to 3	1	2 to 3	1	2	2
Cross-sectional area size range	mm <sup>2</sup>	1.0 to 2.5	4 to 35	4 to 16	1 to 1.5	1 to 2.5	1.5	1.5 to 2.5	1.5 to 2.5
<b>Method of installation:<sup>C)</sup></b>									
In conduit		+	+	+	+	+	+	+	+
In cable trunking		+	+	+	+	+	+	+	+
In cable ducting		+	+	+	+	+	+	+	+
Clipped direct		+	+	+	+	+	+	+	+
On cable tray		+	+	+	+	+	+	+	+
Embedded		+	+	+	+	+	+	+	+
<b>Temperature:</b>									
Maximum continuous conductor operating <sup>D)</sup>	°C	70	70	70	70	70	70	70	70
Maximum conductor short circuit (Maximum allowable time 5 s)	°C	160	160	160	160	160	160	160	160
Maximum overload (Maximum allowable time 4 h)	°C	115	115	115	115	115	115	115	115
Maximum cable surface <sup>E)</sup>	°C	70	70	70	70	70	70	70	70
Maximum storage	°C	40	40	40	40	40	40	40	40
Minimum installation and handling	°C	5	5	5	5	5	5	5	5

**NOTE** For the relevant parameter "+" indicates acceptable practice.

<sup>A)</sup> These are UK cable codes.

<sup>B)</sup> Conductor class designations:

- 1 = solid wire;
- 2 = stranded (rigid).

<sup>C)</sup> The presence of water in contact with the cable is not acceptable.

<sup>D)</sup> The maximum conductor temperature at which the particular cable should operate depends on the limiting temperature of the other cables and accessories with which it is in contact.

<sup>E)</sup> See BS 7540-1.

Table C.2 Construction details, method of installation and temperature for Table 6

Parameter	Unit	Table 6		
		3182A <sup>A)</sup>	3183A <sup>A)</sup> 3184A 3185A	3192A <sup>A)</sup>
<b>Construction details:</b>				
Nominal voltage rating	V	300/500	300/500	300/500
Conductor class <sup>B)</sup>		5	5	5
Number of cores		2	3 to 5	2
Cross-sectional area size range	mm <sup>2</sup>	0.5 <sup>C)</sup> to 4	0.75 to 4	0.75 to 1.0
<b>Duty:</b> <sup>D)</sup>				
Extra light		+	+	+
Light		+	+	+
Ordinary		+	+	+
Heavy		-	-	-
<b>Presence of water:</b>				
Condition AD1		+	+	+
Condition AD2		+	+	+
Condition AD6		-	-	-
Condition AD7		-	-	-
Condition AD8		-	-	-
<b>Corrosive or polluting substances condition AF3</b>				
<b>Impact condition AG2</b>				
<b>Vibrations condition AH3</b>				
<b>Flora condition AN2</b>				
<b>Fauna condition AL2</b>				
<b>Solar radiation condition AN2</b>				
<b>Outdoor use:</b>				
Intermittent and temporary periods of short duration		+	+	+
Permanent		-	-	-
<b>Flexing and torsion:</b>				
Frequent flexing <sup>D)</sup>		+	+	+
Frequent torsion <sup>D)</sup>		+	+	-
<b>Temperature:</b>				
Maximum continuous conductor operating <sup>E)</sup>	°C	60	60	60
Maximum conductor short circuit (Maximum allowable time 5 s)	°C	160	160	160
Maximum cable surface	°C	50	50	50
Maximum storage	°C	40	40	40
Minimum installation and handling	°C	-25	-25	-25

**NOTE** For the relevant parameter "+" indicates acceptable practice and "-" indicates not acceptable practice.

<sup>A)</sup> These are UK cable codes.

<sup>B)</sup> Conductor class designations:

- 5 = flexible.

<sup>C)</sup> Cables with a cross-sectional area of 0.5 mm<sup>2</sup> should be used in lengths not exceeding 2 m and their current should not exceed 3 A.

<sup>D)</sup> See BS 7540-1.

<sup>E)</sup> The maximum conductor temperature at which the particular cable should operate depends on the limiting temperature of the other cables and accessories with which it is in contact.

Table C.3 Guide to use

Table	Cable type	Recommendations for use	Comments
3, 4 and 5	Single core, flat twin and 3-core, PVC sheathed, with and without protective conductor.	These cables are suitable for fixed installation in industrial, commercial and domestic premises, installation in walls, on boards, in conduit, trunking or embedded in plaster.	—
6	Ordinary duty low temperature PVC sheathed circular flexible cable.	<p>The cables are suitable for use on ELV systems (110 V centre tapped) on building sites in the UK; use with temporary traffic light systems when suitably protected; indoor use at low voltage (230 V).</p> <p>The cables are not suitable for outdoor use at voltages greater than 110 V ELV.</p>	<p>Usage on UK building sites, with ELV (110 V centre tapped) might include hand-held tools.</p> <p>Yellow sheath for ELV and site services, etc.</p> <p>Blue sheath for temporary traffic lights, etc.</p>

## Annex D Compatibility test (normative)

### D.1 Principle

This test determines whether the insulation and sheath are likely to deteriorate due to contact with the other components in the cables.

### D.2 Procedure

**D.2.1** Prepare a test sample by ageing it in an air oven in accordance with BS EN 60811-401, 4.2.3.4, for 7 days at  $(80 \pm 2)$  °C. Place a sheet of clean white blotting paper under each test sample in the oven during the ageing to detect any exudation that might drip from the cable.

**D.2.2** After completion of the ageing test, the tensile strength and elongation at break for the insulation and sheath shall conform to the requirements stated in Table D.1 when measured in accordance with BS EN 60811-501.

Table D.1 Compatibility requirements

Component	Parameter	Requirement for material type			
		TI 1	TI 4	Type 6	Type 10
Insulation	Minimum tensile strength (N/mm <sup>2</sup> )	12.5	12.5	—	—
	Minimum percentage elongation at break	125	125	—	—
	Maximum percentage variation <sup>A)</sup> of tensile strength	±20	±20	—	—
	Maximum percentage variation <sup>A)</sup> of elongation at break	±20	±20	—	—
Sheath	Minimum tensile strength (N/mm <sup>2</sup> )	—	—	6.0	10.0
	Minimum percentage elongation at break	—	—	125	150
	Maximum percentage variation <sup>A)</sup> of tensile strength	—	—	±20	±20
	Maximum percentage variation <sup>A)</sup> of elongation at break	—	—	±20	±20

<sup>A)</sup> The variation is the difference between the respective values obtained prior to and after heat treatment, expressed as a percentage of the former.

Annex E  
(normative)**Method of test for voltage withstand****E.1 Sample**

E.1.1 *Sample of completed cable*, not less than 20 m long.

**E.2 Procedure**

Immerse the sample in water at a temperature of  $(20 \pm 5)$  °C for a period of not less than 24 h. Ensure that the ends of the cable protrude above the water by a distance sufficient to prevent excessive surface leakage when the test voltage is applied between the conductor and the water.

Take:

- a) each conductor in turn;
- b) all other conductors, which are connected together and also connected to the water.

Gradually apply a test voltage of 2 000 V between a) and b) and maintain at full r.m.s. value for 15 min.

Repeat the test, but applying the voltage between all conductors connected together and the water.

In both cases earth the circuit protective conductor if present but do not include it in the conductors to be tested. While the sample is still immersed, disconnect the circuit protective conductor from the water and apply a voltage of 1 000 V a.c. for 5 min between this and the water.

Annex F  
(informative)**Notes on type tests****F.1 General**

Type tests, after they have been completed, need not be repeated unless changes have been made that might affect conformity to the test requirements. Type tests should not normally be required on cables for any individual contracts provided that such type tests have already been successfully performed by the manufacturer.

Subclauses **F.2**, **F.3** and **F.4** give guidance as to the amount of type testing that might reasonably be required.

**F.2 Sample selection for type tests**

For type tests on finished cables in Table 3 to Table 5, conformity can be confirmed by selecting one cable with the smallest conductor size and smallest number of cores, and one cable with the largest conductor size and the largest number of cores. To cover the full range of Table 3 to Table 5 a 1 core 1 mm<sup>2</sup> cable from Table 3 and a 3 core 16 mm<sup>2</sup> cable from Table 4 should be selected. If a smaller range is required, then the previous principle for selection should be applied.

For type tests on finished cable in Table 6, conformity can be confirmed by selecting one cable with the smallest conductor size and smallest number of cores, and one cable with the largest conductor size and the largest number of cores.

In addition, where manufacturers want to demonstrate conformity to this British Standard, the cable samples should be subjected to full dimensional checks and to all other sample (S) and routine (R) tests in accordance with Table 2.

### F.3 Type tests

#### F.3.1 Insulation material (see 7.1)

One test should be performed for each grade of insulation material on any one cable from the range of cables selected.

#### F.3.2 Sheath material (see 10.1)

One test should be performed for each grade of sheath material on any one cable from the range of cables selected.

#### F.3.3 Insulation resistance (see 16.2)

One test should be performed on each size of cable selected.

#### F.3.4 Long term resistance to d.c. (see 16.4)

One test should be performed on each size of cable selected.

#### F.3.5 Compatibility test (see 16.5)

One test should be performed on each size of cable selected.

#### F.3.6 Flame propagation on single cable (see 16.6)

One test should be performed on each size of cable selected.

#### F.3.7 Length of lay (see 15.5)

*NOTE This test is classified as a sample test. The guidance given below applies to type testing.*

One test should be performed on each size of cable selected.

#### F.3.8 Flexing test (see 16.7)

One test should be performed on each cable selected.

### F.4 Change of material

The tests referred to in F.3 assume that the materials are consistent throughout the range of cables for which conformity is to be confirmed. Where a change occurs, additional testing should be performed to ensure that such changes are adequately examined.

### F.5 Evidence of type testing

When evidence of type testing is required, this should be stated at the enquiry stage. Due to the possible variations in cable designs, it should not be assumed that full type test information is available for the size and type of cable of a particular enquiry.

A certificate of type test signed by the representative of a competent witnessing body, or a properly authorized report by the manufacturer giving the test results, should be acceptable.

## Bibliography

### Standards publications

- BS 6360, *Specification for conductors in insulated cables and cords*<sup>5)</sup>
- BS 6500, *Electric cables – Flexible cords rated up to 300/500 V, for use with appliances and equipment intended for domestic, office and similar environments*
- BS 7540-1, *Electric cables – Guide to use for cables with a rated voltage not exceeding 450/750 V – Part 1: General guidance (Implementation of CENELEC HD 216 S2)*
- BS 7655-3.1, *Specification for insulating and sheathing materials for cables – Part 3: PVC insulating compounds – Section 3.1: Harmonized types*<sup>6)</sup>
- BS 7671, *Requirements for electrical installations – IET Wiring Regulations – Seventeenth edition*
- BS 7919:2001+A3:2005, *Electric cables – Flexible cables rated up to 450/750 V, for use with appliances and equipment intended for industrial and similar environments*<sup>7)</sup>
- BS EN 50265-2-1, *Common test methods for cables under fire conditions – Test for resistance to vertical flame propagation for a single insulated conductor or cable – Part 2-1: Procedures – 1 kW pre-mixed flame*<sup>8)</sup>
- BS EN 50356, *Method for spark testing of cables*<sup>9)</sup>
- BS EN 50525, *Electric cables – Low voltage energy cables of rated voltages up to and including 450/750 V (U<sub>0</sub>/U)*
- BS EN 50525-2-11, *Electric cables – Low voltage energy cables of rated voltages up to and including 450/750 V (U<sub>0</sub>/U) – Part 2-11: Cables for general applications – Flexible cables with thermoplastic PVC insulation*
- BS EN 50525-2-31, *Electric cables – Low voltage energy cables of rated voltages up to and including 450/750 V (U<sub>0</sub>/U) – Part 2-31: Cables for general applications – Single core non-sheathed cables with thermoplastic PVC insulation*
- BS EN 50525-2-51, *Electric cables – Low voltage energy cables of rated voltages up to and including 450/750 V (U<sub>0</sub>/U) – Part 2-51: Cables for general applications – Oil resistant control cables with thermoplastic PVC insulation*
- HD 21 (all parts), *Cables of rated voltages up to and including 450/750 V and having thermoplastic insulation*
- HD 22 (all parts), *Cables of rated voltages up to and including 450/750 V and having cross-linked insulation*
- HD 516, *Guide to use of low voltage harmonized cables*
- HD 308, *Identification of cores in cables and flexible cords*

<sup>5)</sup> This is referred to in the Foreword only. BS 6360 has been withdrawn and replaced by BS EN 60228.

<sup>6)</sup> This is referred to in the Foreword only. BS 7655-3.1 has been withdrawn and replaced by BS EN 50363-3.

<sup>7)</sup> BS 7919 has been withdrawn and replaced by BS EN 50525-1, BS EN 50525-2-11, BS EN 50525-2-21, BS EN 50525-2-51, BS EN 50525-2-83 and BS EN 50525-3-21.

<sup>8)</sup> This is referred to in the Foreword only. BS EN 50265-2-1 has been withdrawn and replaced by BS EN 60332-1-2.

<sup>9)</sup> This is referred to in the Foreword only. BS EN 50356 has been withdrawn and replaced by BS EN 62230.



www.mcafee.com

# British Standards Institution (BSI)

BSI is the independent national body responsible for preparing British Standards and other standards-related publications, information and services. It presents the UK view on standards in Europe and at the international level.

BSI is incorporated by Royal Charter. British Standards and other standardisation products are published by BSI Standards Limited.

## Revisions

British Standards and PASs are periodically updated by amendment or revision. Users of British Standards and PASs should make sure that they possess the latest amendments or editions.

It is the constant aim of BSI to improve the quality of our products and services. We would be grateful if anyone finding an inaccuracy or ambiguity while using British Standards would inform the Secretary of the technical committee responsible, the identity of which can be found on the inside front cover. Similarly for PASs, please notify BSI Customer Services.

**Tel: +44 (0)20 8996 9001 Fax: +44 (0)20 8996 7001**

BSI offers BSI Subscribing Members an individual updating service called PLUS which ensures that subscribers automatically receive the latest editions of British Standards and PASs.

**Tel: +44 (0)20 8996 7669 Fax: +44 (0)20 8996 7001**

**Email: [plus@bsigroup.com](mailto:plus@bsigroup.com)**

## Buying standards

You may buy PDF and hard copy versions of standards directly using a credit card from the BSI Shop on the website [www.bsigroup.com/shop](http://www.bsigroup.com/shop). In addition all orders for BSI, international and foreign standards publications can be addressed to BSI Customer Services.

**Tel: +44 (0)20 8996 9001 Fax: +44 (0)20 8996 7001**

**Email: [orders@bsigroup.com](mailto:orders@bsigroup.com)**

In response to orders for international standards, BSI will supply the British Standard implementation of the relevant international standard, unless otherwise requested.

## Information on standards

BSI provides a wide range of information on national, European and international standards through its Knowledge Centre.

**Tel: +44 (0)20 8996 7004 Fax: +44 (0)20 8996 7005**

**Email: [knowledgecentre@bsigroup.com](mailto:knowledgecentre@bsigroup.com)**

BSI Subscribing Members are kept up to date with standards developments and receive substantial discounts on the purchase price of standards. For details of these and other benefits contact Membership Administration.

**Tel: +44 (0)20 8996 7002 Fax: +44 (0)20 8996 7001**

**Email: [membership@bsigroup.com](mailto:membership@bsigroup.com)**

Information regarding online access to British Standards and PASs via British Standards Online can be found at [www.bsigroup.com/BSOL](http://www.bsigroup.com/BSOL)

Further information about British Standards is available on the BSI website at [www.bsi-group.com/standards](http://www.bsi-group.com/standards)

## Copyright

All the data, software and documentation set out in all British Standards and other BSI publications are the property of and copyrighted by BSI, or some person or entity that own copyright in the information used (such as the international standardisation bodies) has formally licensed such information to BSI for commercial publication and use. Except as permitted under the Copyright, Designs and Patents Act 1988 no extract may be reproduced, stored in a retrieval system or transmitted in any form or by any means – electronic, photocopying, recording or otherwise – without prior written permission from BSI. This does not preclude the free use, in the course of implementing the standard, of necessary details such as symbols, and size, type or grade designations. If these details are to be used for any other purpose than implementation then the prior written permission of BSI must be obtained. Details and advice can be obtained from the Copyright & Licensing Department.

**Tel: +44 (0)20 8996 7070**

**Email: [copyright@bsigroup.com](mailto:copyright@bsigroup.com)**

## BSI

389 Chiswick High Road London W4 4AL UK

Tel +44 (0)20 8996 9001

Fax +44 (0)20 8996 7001

[www.bsigroup.com/standards](http://www.bsigroup.com/standards)